



## Motorized Pulley 800M, H & 800HD, Ø 800 mm

To match your requirements in diameter 800 mm, our product range offers two different loading performances for your BULK applications:

- 800M, 800H
- 800HD

You have a choice.

Therefore, it is important to notice the differences to choose the right type of pulley for the right application based on estimated belt tension (radial load) = T1+T2. The actual radial load **MUST** be **LESS** than the max. allowable radial load shown in this catalogue.

Be aware of increased belt tensions using **multi-ply thick heavy belts** and/or larger belt widths.

Motor/gearbox of 800M has its origin from 630H.

However, 800H remains top of the range as to design, reinforcement and strength.

800M, H & 800HD are designed for HEAVY DUTY applications and they provide the necessary torque, belt pull and allowable belt tension in order to handle the toughest, irregular & most extreme and brutal working conditions.

### STANDARD SPECIFICATION of Motorized Pulley

- Crowned mild steel Ø 800 mm steel shell painted yellow - min. layer of 60 µm
- Bolted powder coated cast iron bearing housings and covers, all painted yellow – min. layer of 60 µm
- Mild steel shafts
- Shaft sealing system - degree of protection IP66/67 (EN60034-5)
- Cast iron terminal box painted yellow – min. layer of 60 µm
- 3-phase induction motors with thermal protector
- Voltage: 3-phase single voltage. Most common voltages available. Please specify!
- Motor winding insulation Class F
- Dynamically balanced rotor
- Two oil plugs each fitted with a magnet to filter the oil
- Yellow painted cast steel mounting brackets – one type AL & one type ALO
- Oil change recommended every 10,000 operational hours
- Maximum RL – Please inquire!
- Non standard RL's available
- To be used in horizontal positions ±5 degree only!

### Please note:

- Special speeds available on request.
- Environmental considerations: page 77-78
- Technical precautions: pages 81-92
- Optional extras: page 65 and back cover
- Connection Diagrams: page 100.

### SEMI-RUST-FREE options

#### TS11

- Painted mild steel shell – min. layer of 120 µm
- Painted cast iron end housings – min. layer of 120 µm
- Stainless steel covers with labyrinth grooves – AISI 304 range
- Nitrided shaft sleeves
- Zinc-plated oil plugs – each with magnet
- Zinc-plated exterior bolts
- Shaft sealing system – degree of protection IP66/67 (EN60034-5)
- Painted terminal box – min. layer of 120 µm
- Nickel plated mounting brackets with labyrinth grooves

#### TS12

- As TS11, but without re-greasable seals.
- Covers - standard

### Please note:

- FDA & USDA food grade recognized oil and grease are NOT included in TS11 & TS12, but available on request.

**Please specify required TS-number when ordering!**



## OPTIONAL EXTRAS

### Motorized Pulley 800M, H & 800HD

Specification	800M	800H/HD
Semi-rust-free option                      Re-greasable labyrinth seals!	TS11	TS11
Semi-rust-free option                      Standard seals!	TS12	TS12
Dust explosion proof Motorized Pulleys - ATEX 95 - Zone 22 - for applications handling of dusty grain etc. According to European Directive 94/9/EC.	On request!	On request!
Re-greasable labyrinth seals - mild steel	x	x
Black rubber lagging - STANDARD specifications: - Smooth lagging - Hardness 60 ±5 Shore A - Diamond lagging - Hardness 60 ±5 Shore A	o 10 mm 10 mm	o 10 mm 10 mm
White smooth rubber lagging (FDA). Oil, fat & grease resistant	x	x
SPECIAL lagging available on request - e.g. hot vulcanized, ceramic etc.	x	x
External brake shaft for connection to mechanical brake	x	x
Mechanical backstop	x	x
Insulation class F - Allowable ambient temperature: -25°C-+40°C	Std.	Std.
Insulation class H with synthetic oil	x	x
Parallel shell	x	x
Thermal protector	Std.	Std.
IP66/67 cast iron terminal box painted yellow	Std.	Std.
Shaft sealing system - degree of protection IP66/67 (EN60034-5)	Std.	Std.
3-phase single voltage (3x230-400V or 400-690V 50Hz) with +/-10% tolerance - DIN IEC 38	Std.	Std.
Special voltages - 50 and/or 60Hz                      Please specify!	x	x
Dual voltage - delta/star - connection possibility!	x	x
CSA approved motors - available on request only!	x	x

**x** = Optional extra's

**o** = An option with certain limitations. Please refer to Technical precautions pages 81-92!

**Std.** = Fitted as standard

## Motorized Pulley 800M, H & 800HD, Ø 800 mm

Motorized Pulley  
with terminal box

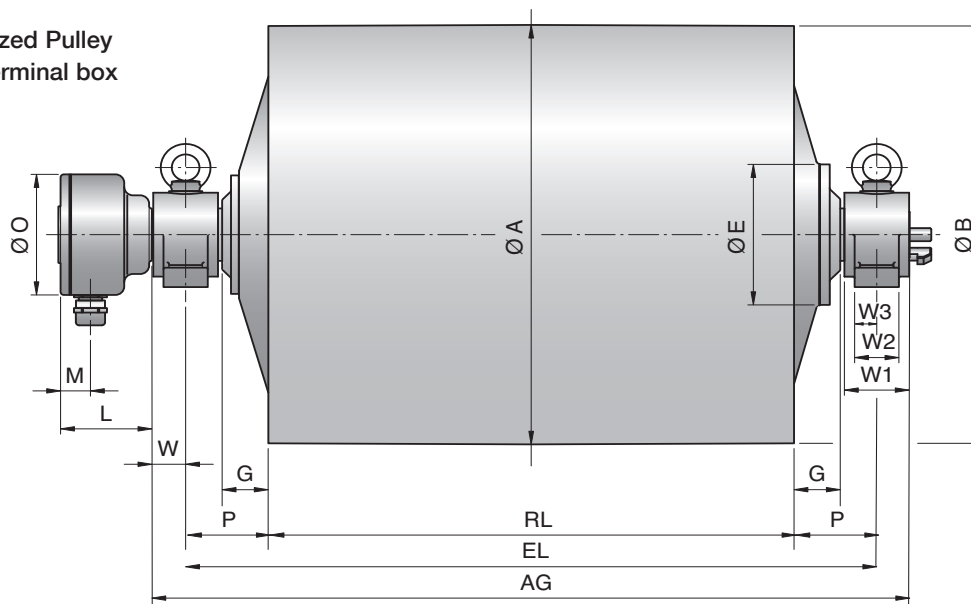

Idler Pulley  
UT630M / UT630H

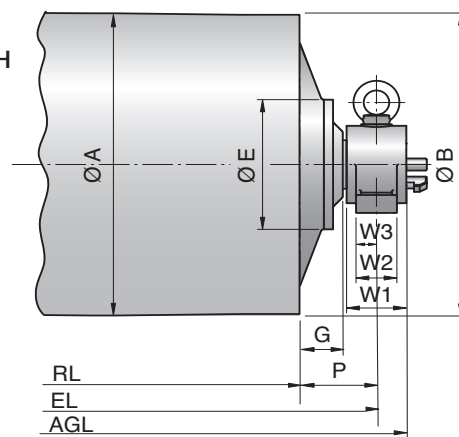

Type	A mm	B mm	C mm	D mm	E mm	G mm	L mm	M mm	O mm	P mm
800M	800	796	-	90	268	88	165	54	230	150
800H/HD	800	796	-	120	330	80	200	62	260	150
UT630M	630	626	-	90	226	85	-	-	-	150
UT630H	630	626	-	120	330	75	-	-	-	150

Mounting brackets  
AL90 & ALO90  
AL120 & ALO120  
AL121 & ALO121

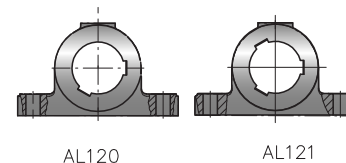
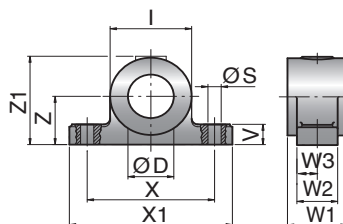

Motorized Pulleys & Idler Pulleys (UT) Type	Material	Bracket description	Dimensions											Weight kg	
			D mm	I mm	S mm	V mm	W mm	W1 mm	W2 mm	W3 mm	X mm	X1 mm	Z mm		Z1 mm
800M & UT630M	Cast steel	AL90/ALO90	90	160	26	42	58.5	117	80	58.5	250	320	100	183	19.0
800H & UT630H	Cast steel	AL120/ALO120	120	200	33	50	95	160	120	65.0	300	370	110	213	38.0



## Motorized Pulley 800M, Ø 800 mm

50 Hz

Motor Power kW/HP	No. of Poles	Gear stage	Nominal belt speed at Full Load 50Hz m/sec	Torque Nm	Belt Pull N	Max. Radial Load T1+T2 N	Min. RL	Type	Weight in kg for STANDARD width								Type of Bracket
									Dimension RL in mm (RL >2000 mm available on request)								
									950	1000	1050	1100	1150	1200	1250	per 50 mm up to 2000	
22.0/30.0	8	2	1.25	6688	16720	73600	950	800M	935	948	960	973	985	995	1005	13 kg	AL90/ALO90
			1.60	5223	13058												
			2.00	4178	10445												
			2.50	3343	8358												
			3.15	2653	6633												
30.0/40.0	8	2	1.60	7122	17805	98100	950	800M	975	988	1000	1013	1025	1035	1045	13 kg	AL90/ALO90
			2.00	5698	14245												
			2.50	4558	11395												
			3.15	3617	9043												
37.0/50.0	6	2	2.00	7030	17575	98100	950	800M	975	988	1000	1013	1025	1035	1045	13 kg	AL90/ALO90
			2.50	5622	14055												
			3.15	4462	11155												
			4.00	3513	8783												
45.0/61.0	4	2	3.15	5426	13565	88300	950	800M	995	1008	1020	1033	1045	1055	1065	13 kg	AL90/ALO90
			4.00	4273	10683												
55.0/75.0	4	2	3.15	6584	14581	88300	950	800M	995	1008	1020	1033	1045	1055	1065	13 kg	AL90/ALO90
			4.00	5223	13058												
<b>Idler Pulley</b>						98100	750	UT630M	327	336	345	354	362	371	380	9 kg	AL90/ALO90

## Motorized Pulley 800H/HD, Ø 800 mm

50 Hz

Motor Power kW/HP	No. of Poles	Gear stage	Nominal belt speed at Full Load m/sec	Torque Nm	Belt Pull N	Max. Radial Load T1+T2 N	Min. RL	Type	Weight in kg for STANDARD width								Type of Bracket												
									Dimension RL in mm (RL >2000 mm available on request)																				
									1400	1450	1500	1550	1600	1650	1700	per 50 mm up to 2000													
55.0/75.0	8	3	1.00	20884	54974	200000	1300	800HD	2390	2420	2450	2455	2485	2515	2546	30kg	AL121/ALO121												
	6		1.25	16707	41300																								
	8		1.60	13052	32630																								
55.0/75.0	6	2	2.00	10450	26125	200000	1150	800H	2150	2175	2200	2225	2250	2275	2300	25 kg	AL120/ALO120												
			2.50	8360	20900																								
			3.15	6635	16588																								
			4.00	5225	13063																								
			4.50	4644	11610																								
75.0/100.0	6	3	1.25	22527	56318	200000	1300	800HD	2390	2420	2450	2455	2485	2515	2546	30kg	AL121/ALO121												
			1.60	18496	46240																								
			2.00	14244	35610																								
			2.50	11395	28488																								
			3.15	9044	22610																								
75.0/100.0	6	2	4.00	7122	17805	200000	1150	800H	2150	2175	2200	2225	2250	2275	2300	25 kg	AL120/ALO120												
			4.50	6331	15828																								
			1.60	21181	52953													200000	1550	800HD									
			2.00	18496	46240																								
			2.50	13674	34185																								
3.15	10852	27130																											
4.00	8546	21365																											
90.0/120.0	6	2	4.50	7597	18993	200000	1400	800H	2200	2225	2250	2275	2300	2325	2350	25 kg	AL120/ALO120												
			2.00	21915	54789													180000	1550	800HD									
			2.50	17994	44984																								
			3.15	13264	33160																								
			4.00	10445	26113																								
4.50	9265	23163																											
110.0/150.0	4	3	2.50	21592	53981	180000	1550	800HD																					
			3.15	15153	37882																								
			4.00	12535	31338																								
132.0/180.0	4	2	4.50	11142	27855	180000	1400	800H	2215	2240	2265	2290	2315	2340	2365	25 kg	AL120/ALO120												
			2.50	21592	53981																								
<b>Idler Pulley</b>						200000	1150	UT630H	700	715	730	745	760	775	790	15 kg	AL120/ALO120												

Sectional drawings: please refer to pages 68-70!