



Motorized Pulley 320L, 320M & 320H, Ø 320 mm

To match your requirements in diameter 320 mm, our product range offers three different loading performances for your BULK applications:

- L for Light-duty
- M for Medium-duty
- H for Heavy-duty

You have a choice.

Therefore, it is important to notice the differences to choose the right type of Pulley for the right application based on estimated belt tension (radial load) = T1+T2. The actual radial load **MUST** be **LESS** than the max. allowable radial load shown in this catalogue.

Be aware of increased belt tensions using **multi-ply thick heavy belts** and/or larger belt widths.

If you do not find the belt tension needed in this diameter, you might have to choose a larger one.

L for Light-duty

320L is meant for applications with regular and constant operating conditions. Max. allowable radial load has to be respected; therefore it is advisable to rubber lag these Pulleys to **increase** grip and to **limit** belt tension.

320L should NOT be used for e.g. feeder conveyors.

(Motor/gearbox origin from 220M).

M for Medium-duty

The internal parts of 320M are designed for TOUGH and IRREGULAR working conditions - e.g. in crusher & screening applications, asphalt, cement and concrete plants etc.

H for Heavy-duty

Due to a solid 3-stage gearbox, Ø 50 mm shafts, matching bearings etc, 320H provides the necessary forces needed for low speeds combined with high power, and is designed to handle irregular loadings in BRUTAL conditions.

STANDARD SPECIFICATION of Motorized Pulley

- Crowned mild steel Ø 320 mm steel shell treated with anti-rust wax
- Powder coated cast iron bearing housings
- Mild steel shafts treated with anti-rust wax
- Shaft sealing system – degree of protection IP66/67 (EN60034-5)
- Compact powder coated die cast aluminium terminal box ≤=4.0 kW
- Larger Powder coated die cast aluminium terminal box ≥=5.5 kW
- 3-phase induction motors with thermal protector
- Voltage: wide range 3-phase single voltage. Most common voltages available. Please specify!
- Motor winding insulation Class F
- Dynamically balanced rotor
- One out of two oil plugs fitted with a magnet to filter the oil – 320L
- Two oil plugs fitted with a magnet to filter the oil – 320M & 320H
- Oil change recommended every 10,000 operational hours
- Minimum RL. Please refer to pages 33-34
- Maximum RL – Please inquire!
- Non standard RL's available
- To be used in horizontal positions ± 5 degree only!

Please note:

- Straight or elbow connector available
- Parallel shell available. Diameter equal to dimension Ø A
- Two speed motors on request
- Special speed available on request
- Motorized Pulleys for non-horizontal positions available on request
- The high speed of 2-pole motors can cause higher noise levels and are therefore not recommended in noise sensitive areas
- Environmental considerations: page 77-78
- Technical precautions: pages 81-92
- Optional extras: page 31 and back cover
- Connection Diagrams: pages 98-100.

STAINLESS STEEL options

TS9N

- Stainless steel shell – AISI 304 range
- Stainless steel shafts – AISI 303/4 range
- Stainless steel covered bearing housings – AISI 316 range
- Stainless steel oil plugs – AISI 304 range – one out of two with magnet
- Stainless steel exterior bolts – AISI 304 range
- Re-greasable labyrinth seals with grease nipples in stainless steel – AISI 304 range
- Shaft sealing system – degree of protection IP66/67 (EN60034-5).

TS10N

- As TS9N, but WITHOUT re-greasable labyrinth seals.

SEMI-RUST-FREE options

TS11N

- As TS9N, but with crowned mild steel Ø 320 mm steel shell treated with anti-rust wax.

TS12N

- As TS10N, but with crowned mild steel Ø 320 mm steel shell treated with anti-rust wax.

Other Options:

- FDA & USDA food grade recognized oil and grease are NOT included in TS9N to TS12N, but available on request
- Complete Motorized Pulleys in acid resistant stainless steel – AISI 316 range – on request.

Electrical connection options:

- Salt water resistant powder coated aluminium terminal box with zinc plated exterior bolts
- Stainless steel terminal box – AISI 304 range (max. 4 kW)
- Straight stainless steel connector with flying lead – AISI 304 range.

Please specify required TS-number when ordering!



OPTIONAL EXTRAS

Motorized Pulley 320L, 320M & 320H

Specification	320L	320M & 320H
Total stainless steel option AISI 304 range TS9N Re-greasable labyrinth seals!	x	x
Total stainless steel option AISI 304 range TS10N Standard seals!	x	x
Semi-rust-free option TS11N Re-greasable labyrinth seals!	x	x
Semi-rust-free option TS12N Standard seals!	x	x
Food grade oil & grease - FDA & USDA recognized - available on request	x	x
Dust explosion proof Motorized Pulleys - ATEX 95 - Zone 22 - for applications handling of dusty grain etc. According to European Directive 94/9/EC.	On request!	On request!
TOTAL acid resistant stainless steel option - AISI 316	x	x
Re-greasable labyrinth seals - mild steel	x	x
Black rubber lagging - STANDARD specifications: - Smooth lagging - Hardness 60 ±5 Shore A - Diamond lagging - Hardness 60 ±5 Shore A	o 5/8 mm 6/8 mm	o 5/8 mm 6/8 mm
White smooth rubber lagging (FDA). Oil, fat & grease resistant	x	x
SPECIAL lagging available on request - e.g. hot vulcanized, ceramic etc.	x	x
Electromagnetic brake	x	x
Min. RL dimensions increases by (mm)	100	100
Mechanical backstop	x	x
Min. RL dimensions increases by (mm)		50
Modified for vertical mounting	o	o
Modified for mounting between 5° - ≤ 90° - e.g. for magnetic separators	o	o
Insulation class F - Allowable ambient temperature: -25°C-+40°C	Std.	Std.
Insulation class H with synthetic oil	x	x
SPECIAL motors for applications with NO belt contact	x	x
Low noise drives for noise sensitive areas	x	x
Parallel shell	x	x
Thermal protector	Std.	Std.
IP66/67 Compact powder coated aluminium terminal box - food grade approved	Std.	Std. ≤ 4.0 kW
IP66/67 Compact stainless steel - AISI 304 or 316 range - terminal box	x	≤ 4.0 kW
IP66/67 Larger powder coated aluminium terminal box - food grade approved		Std. ≥ 5.5 kW
Straight or elbow connector with flying lead	x	≤ 4.0 kW
Straight connector with flying lead - Stainless steel - AISI 304 range -	x	≤ 4.0 kW
Shaft sealing system - degree of protection IP66/67 (EN60034-5)	Std.	Std.
Screened cables - a MUST together with Frequency Converters	x	x
3-phase single voltage 3 x 230-400V or 660-690V 50Hz +/- 10% - DIN IEC 38	Std.	Std.
Euro wide range voltage (3 x 380-415V 50 Hz) with +/-10% tolerance - DIN IEC 38 or (3 x 660-690V 50 Hz)	Std.	Std.
Special voltages - 50 and/or 60 Hz Please specify!	x	x
Dual voltage - delta/star - connection!	x	x
CSA approved motors - available on request only!	x	x

x = Optional extra's

o = An option with certain limitations. Please refer to Technical precautions pages 81-92!

Std. = Fitted as standard

Motorized Pulley 320L, 320M & 320H, Ø 320 mm

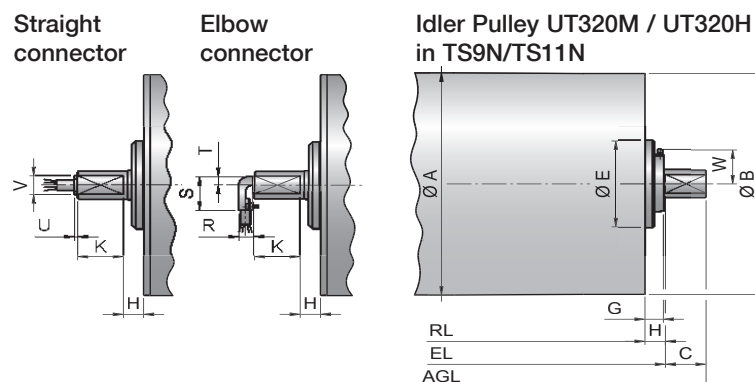
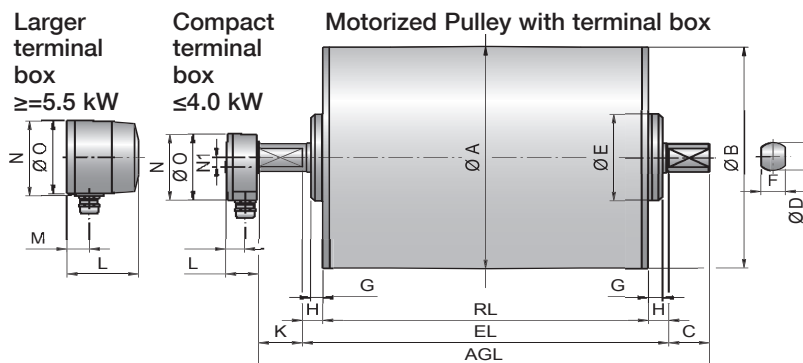

Type	Motorized Pulley or idler Pulley (UT)											Compact terminal box ≤4.0 kW				Larger terminal box ≥5.5 kW				Straight connector ≤4.0 kW		Elbow connector ≤4.0 kW		
	A	B	C	D	E	F	G	TS9/11	H	K	W	L	M	N	N1	L	M	N	O	U	V	R	S	T
	mm	mm	mm	mm	mm	mm	mm	mm	mm	mm	mm	mm	mm	mm	mm	mm	mm	mm	mm	mm	mm	mm	mm	mm
320L	323	319	50	40	96	30	15	19.5	25	54	-	41	24	95	14	-	-	-	-	4	27	20	48	12
320M	321	319	50	40	125	30	17.5	22.5	25	54	-	41	24	95	14	87	27	107	105	4	27	20	48	12
320H	321	319	50	50	148	40	11	20.5	25	54	-	41	24	95	14	87	27	107	105	4	27	20	48	12
UT320M	321	319	50	40	125	30	14.5	22.5	25	-	52	→ Idler Pulley shown in TS9N/TS11N version with re-greasable seals												
UT320H	321	319	50	50	148	40	11	20.5	25	-	52	→ Idler Pulley shown in TS9N/TS11N version with re-greasable seals												

Mounting brackets KL41-HD & KL42

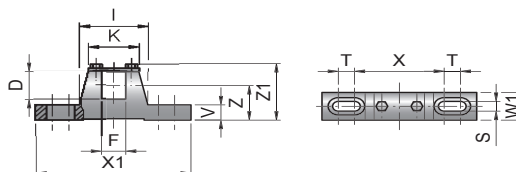

Motorized Pulleys Type	Material	Bracket description	Dimensions												Weight kg
			D	F	I	K	S	T	V	W1	X	X1	Z	Z1	
			mm	mm	mm	mm	mm	mm	mm	mm	mm	mm	mm	mm	mm
320L & 320M	Steel	KL41-HD	40	30	84	62	14	20	22	40	110	190	50	83	2.1
320H	Steel	KL42	50	40	121	90	18	30	25	50	150	250	70	110	4.5



Motorized Pulley 320L, Ø 320 mm

50 Hz

Motor			Nominal belt speed at Full Load 50Hz m/sec	Torque Nm	Belt Pull N	Max. Radial Load T1+T2 N	Special min. RL	Type	Weight in kg for STANDARD width											Type of Bracket
Power kW/HP	No. of Poles	Gear stages							Dimension RL in mm (RL >2000 mm available on request)											
									400	450	500	550	600	650	700	750	800	850	per 50 mm up to 2000	
0.75/1.00	8	2	0.32	356	2218	11500	450	320L	78	82	86	90	94	98	102	106	110	4 kg	KL41-HD	
			0.40	285	1776															
			0.50	228	1421															
			0.63	181	1128															
			0.80	142	885															
			1.00	114	710															
1.10/1.50	4	2	0.63	265	1651	11500	400	320L	73	76	80	84	88	92	96	100	104	108	4 kg	KL41-HD
			0.80	209	1302															
			1.00	167	1040															
			1.25	134	835															
			1.60	105	654															
			2.00	84	524															
1.50/2.00	4	2	0.63	362	2255	11500	400	320L	75	78	82	86	90	94	98	102	106	110	4 kg	KL41-HD
			0.80	285	1776															
			1.00	228	1421															
			1.25	182	1134															
			1.60	143	891															
			2.00	114	710															
2.20/3.00	4	2	0.80	418	2604	11500	450	320L	82	86	90	94	98	102	106	110	114	4 kg	KL41-HD	
			1.00	334	2081															
			1.25	265	1651															
			1.60	209	1302															
			2.00	167	1040															
			2.50	134	835															
3.00/4.00	4	2	1.25	362	2255	11500	500	320L	90	94	98	102	106	110	114	118	4kg	KL41-HD		
			1.60	285	1776															
			2.00	228	1421															
			2.50	182	1134															
4.00/5.50	2	2	1.60	380	2368	11500	500	320L	90	94	98	102	106	110	114	118	4kg	KL41-HD		
			2.00	304	1894															
			2.50	243	1514															

Motorized Pulley 320M & 320H, Ø 320 mm

50 Hz

Motor			Nominal belt speed at Full Load 50Hz m/sec	Torque Nm	Belt Pull N	Max. Radial Load T1+T2 N	Special min. RL	Type	Weight in kg for STANDARD width											Type of Bracket
Power kW/HP	No. of Poles	Gear stages							Dimension RL in mm (RL >2000 mm available on request)											
									450	500	550	600	650	700	750	800	850	per 50 mm up to 2000		
0.75/1.00	12	3	0.13	876	5475	35000	550	320H	135	139	144	149	154	159	164	5 kg	KL42-HD			
			0.16	712	4453															
			0.20	570	3562															
		1.10/1.50	8	2	0.25	456	2841	20000	500	320M	110	114	118	122	126	130	134	138	4 kg	KL41-HD
					0.32	356	2218													
					0.40	285	1776													
0.50	228				1421															
0.63	181				1128															
0.80	142				885															
1.10/1.50	12	3	0.13	1286	8039	35000	550	320H	135	139	144	149	154	159	164	5 kg	KL42-HD			
			0.16	1045	6531															
			0.20	836	5225															
		1.10/1.50	8	2	0.25	669	4181	20000	500	320M	110	114	118	122	126	130	134	138	4 kg	KL41-HD
					0.32	522	3252													
					0.40	418	2604													
0.50	334				2081															
0.63	265				1651															
0.80	209				1302															
1.00	167	1040																		
1.25	134	835																		

Idler Pulley	20000	450	UT320M	50	54	58	62	66	70	74	78	82	4 kg	KL41-HD
		35000	450	UT320H	50	61	65	69	73	77	81	85	89	4 kg



Motorized Pulley 320M & 320H, Ø 320 mm

50 Hz

Power kW/HP	Motor		Nominal belt speed at Full Load 50Hz m/sec	Torque Nm	Belt Pull N	Max. Radial Load T1+T2 N	Special min. RL	Type	Weight in kg for STANDARD width											Type of Bracket																
	No. of Poles	Gear stages							Dimension RL in mm (RL >2000 mm available on request)																											
									450	500	550	600	650	700	750	800	850	per 50 mm up to 2000																		
1.50/ 2.00	8	3	0.16	1425	8906	35000	550	320H	[shaded]	[shaded]	135	139	144	149	154	159	164	5 kg	KL42-HD																	
			0.20	1140	7125																															
		0.25	912	5700																																
	1.50/ 2.00	8	2	0.32	712	4436	20000	500	320M	[shaded]	110	114	118	122	126	130	134	138	4 kg	KL41-HD																
				0.40	570	3551																														
				0.50	456	2841																														
			2.20/ 3.00	8	3	0.20															1672	10450	35000	550	320H	[shaded]	[shaded]	135	139	144	149	154	159	164	5 kg	KL42-HD
0.25						1338															8362															
0.32					1045	6531																														
2.20/ 3.00				8	2	0.40															836	5225	20000	500	320M	[shaded]	110	114	118	122	126	130	134	138	4 kg	KL41-HD
	0.50	669				4181																														
	0.63	522				3252																														
	3.00/ 4.00	4			2	0.80	418	2604	20000	500	320M	[shaded]	100	104	108	112	116	120	124	128	4 kg	KL41-HD														
			1.00			334	2081																													
			1.25		265	1651																														
		3.00/ 4.00	4		3	0.25	1824	11400																												
0.32				1425		8906																														
0.40				1140		7125																														
3.00/ 4.00				4	2	0.50	912	5700															20000	500	320M	[shaded]	100	104	108	112	116	120	124	128	4 kg	KL41-HD
	0.63					727	4525																													
	0.80					570	3562																													
	4.00/ 5.50				4	2	1.00	456	2841	20000	500	320M	[shaded]	110	114	118	122	126	130	134	138	4 kg														
		1.25	362				2255																													
		1.60	285			1776																														
		4.00/ 5.50	4		3	2.00	228	1421	35000																											
2.50				182		1134																														
0.32				1900		11875																														
4.00/ 5.50				4	2	0.40	1520	9499															20000	500	320M	[shaded]	110	114	118	122	126	130	134	138	4 kg	KL41-HD
	0.50					1216	7600																													
	0.63					965	6031																													
	5.50/ 7.50				4	3	0.80	760		4735	35000	550	320H	[shaded]	[shaded]	135	139	144	149	154	159	164														
		1.00	608				3788																													
		1.25	486			3028																														
		5.50/ 7.50	4		2	1.60	380	2368	20000	500																										
2.00				304		1894																														
2.50				243		1514																														
7.50/ 10.00				2	3	0.80	1424	8909															35000	550	320H	[shaded]	[shaded]	135	139	144	149	154	159	164	5 kg	KL42-HD
	1.00					1140	7125																													
	1.25				911	5700																														
	7.50/ 10.00			2	2	1.60	712	4453			20000	500	320M	[shaded]	110	114	118	122	126	130	134	138														
		2.00	570			3562																														
		2.50	456			2850																														
		11.00/ 15.00	2		3	1.00	1672	10450	35000	1100																										
1.25						1327	8294																													
1.60						1045	6531																													
2.00					836	5225																														
2.50	671			4180																																
11.00/ 15.00	2	2	2.50	671	4180	20000	800	320M	[shaded]	[shaded]	[shaded]	[shaded]	[shaded]	[shaded]	[shaded]	[shaded]	[shaded]	[shaded]	[shaded]	[shaded]	173	178	4 kg	KL41-HD												

Idler Pulley	20000	450	UT320M	50	54	58	62	66	70	74	78	82	4 kg	KL41-HD
		35000	450	UT320H	57	61	65	69	73	77	81	85	89	4 kg

Motorized Pulley 320L, Ø 320 mm

Spare parts list and sectional drawings

Pos.	Description	Pos.	Description	Pos.	Description
1	Shell	24	2 Dust lip seals each side	78	Gasket
2	End housing with geared rim	24	1 Double lip seal for labyrinth option	79	Holding clip or plastic tie
3	End housing	25	O-ring	85.1	Intermediate flange for brake assembly
8	Geared rim	26	Bearing	91	Electromagnetic brake
9	Rotor pinion	27	Bearing	93	Retaining ring
10	Input wheel	28	Bearing	95	Straight connector
11	Output pinion	29	Bearing (Backstop solution: One-way-bearing)	96	Elbow connector
12	Gear box	30	Bearing	101	Key
13	Front shaft	31	Bearing	104	Distance washer
14	Rear shaft	39	Hexagon socket screw	120	Labyrinth cover
15	Stator complete	40	Hexagon socket screw	121	Set screw
15.1	Rotor	52	Magnetic oil plug	122	O-ring
16	Terminal box complete	53	Distance washer	123	Grease nipple
17	Nipple	53.1	Compression nipple	143	O-ring
20	Cover	59	Countersunk head screw	146	Special shaped compression washer
20.1	Cover with labyrinth groove	66	Waved spring washer	200	Rubber seal
23	Rear flange	68	Key	202	Motor data plate
23.1	Rear flange for backstop	70	Toothed washer		
23.2	Rear flange for electromagnetic brake				

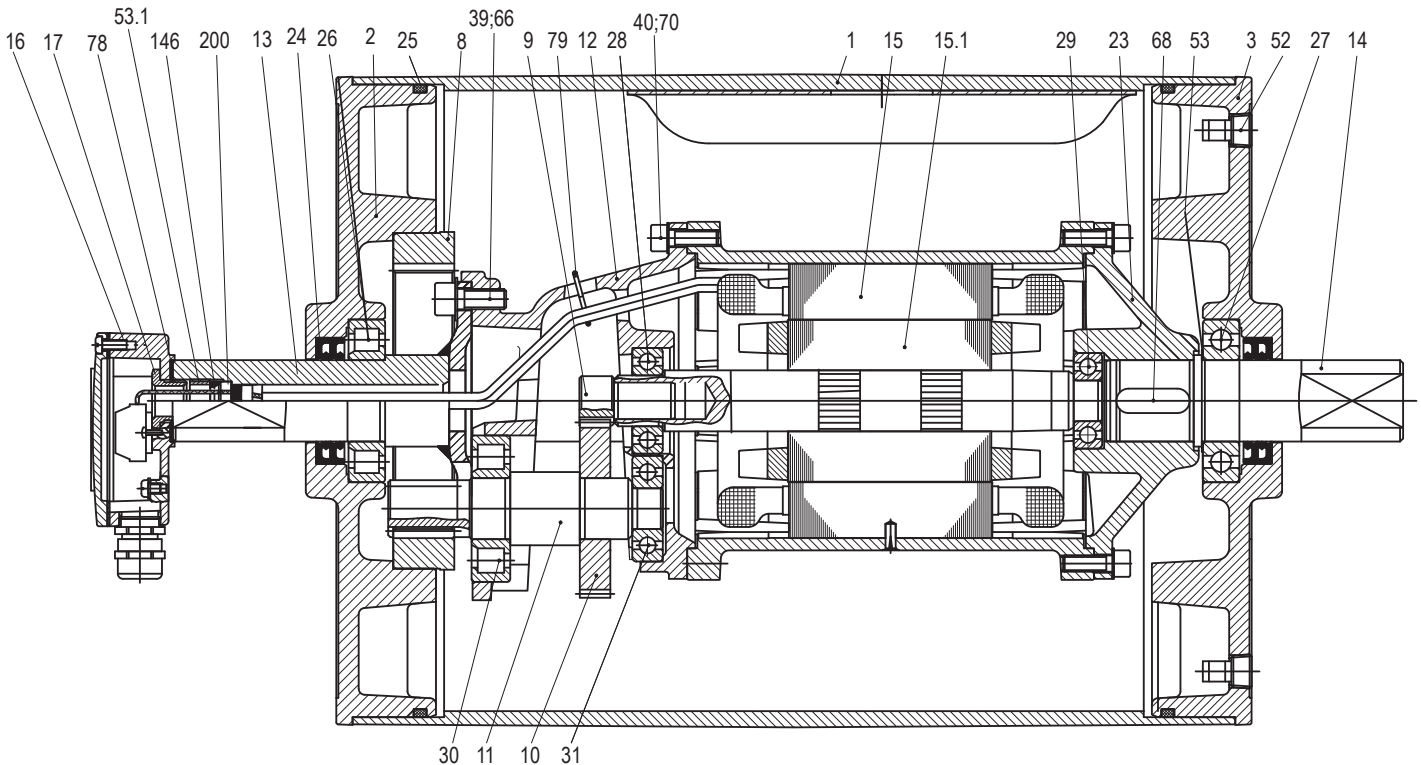

Motorized Pulley 320M, Ø 320 mm

Spare parts list and sectional drawings

Pos.	Description	Pos.	Description	Pos.	Description
1	Shell	28	Bearing	70	Toothed washer
2	End housing with geared rim	29	Bearing	75	Gasket
3	End housing	30	Bearing	78	Gasket
8	Geared rim	30	Bearing	79	Holding clip or plastic tie
9	Rotor pinion	31	Bearing	81	Rotor pinion shaft
10	Input wheel	32	Retaining ring	85	Intermediate flange for backstop
11	Output pinion	33	Retaining ring	85.1	Intermediate flange for brake assembly
12	Gear box	35	Retaining ring	90	Backstop
13	Front shaft	37	Hexagon head screw	91	Electromagnetic brake
14	Rear shaft	43	Hexagon head screw	93	Retaining ring
15	Stator complete	44	Hexagon head screw	94	Hexagon head screw
15.1	Rotor	45	Hexagon head screw	95	Straight connector
16	Terminal box complete	46	Hexagon head screw	96	Elbow connector
17	Nipple	52	Magnetic oil plug	99	Waved spring washer
20	Cover	53	Distance washer	101	Key
20.1	Cover with labyrinth groove	53.1	Compression nipple	104	Distance washer
23	Rear flange	60	Parallel pin	120	Labyrinth cover
23.1	Rear flange for backstop/Brake	64	Prevailing torque type hexagon nut	121	Set screw
24	2 Dust lip seals each side	66	Waved spring washer	122	O-ring
25	O-ring	67	Toothed washer	123	Grease nipple
26	Bearing	68	Key	143	O-ring
27	Bearing	69	Key	146	Special shaped compression washer
				200	Rubber seal

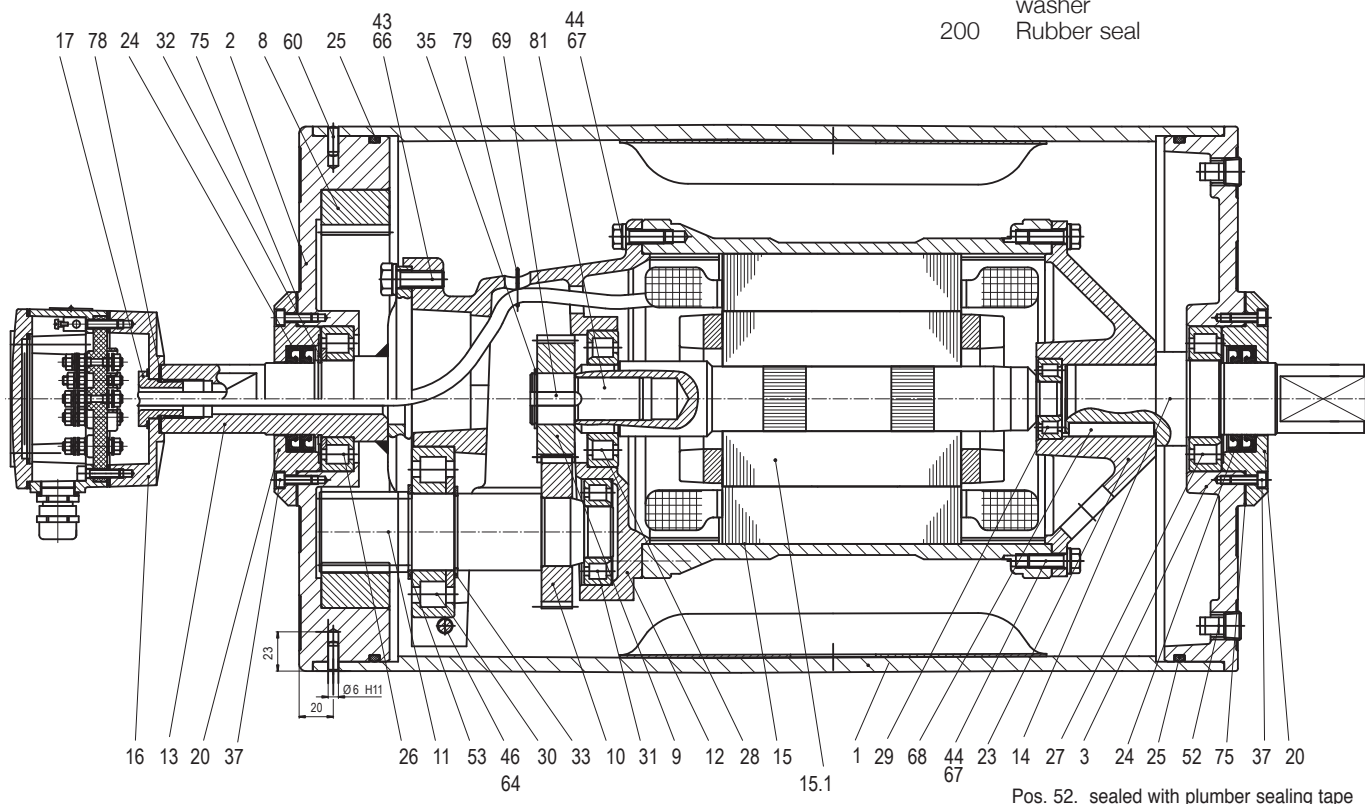

Motorized Pulley 320H, Ø 320 mm

Spare parts list and sectional drawings

Pos.	Description	Pos.	Description	Pos.	Description
1	Shell	90	Backstop	184	Bearing
2	End housing with geared rim	91	Electromagnetic brake	185	Bearing
3	End housing	93	Retaining ring	186	Key
8	Geared rim	94	Hexagon head screw	187	Key
9	Rotor pinion	95	Straight connector	188	Retaining ring
10	Input wheel	96	Elbow connector	189	Retaining ring
11	Output pinion	99	Waved spring washer	190	Retaining ring
12	Gear box	101	Key	191	Retaining ring
13	Front shaft	104	Distance washer	192	Retaining ring
14	Rear shaft	120	Labyrinth cover	193	Distance washer
15	Stator complete	121	Set screw	194	Set screw
15.1	Rotor	122	O-ring	195	Prevailing torque type hexagon nut
16	Terminal box complete	123	Grease nipple	196	Key
17	Nipple	143	O-ring	197	Retaining ring
20	Cover front side	146	Special compression washer	198	Distance ring
20.1	Cover with labyrinth groove	180	Intermediate pinion shaft	199	Bushing (inner race of the needle roller bearing)
21	Cover – rear side	181	Intermediate pinion	200	Rubber seal
21.1	Cover with labyrinth groove	182	Distance bushing	201	Hexagon head screw
23	Rear flange	183	Washer		
23.1	Rear flange for brake option				
24	2 Dust lip seals each side				
25	O-ring				
26	Bearing				
27	Bearing				
28	Bearing				
29	Bearing				
30	Bearing				
31	Bearing				
32	Retaining ring				
33	Retaining ring				
35	Retaining ring				
37	Hexagon socket screw				
38	Hexagon socket screw				
43	Hexagon socket screw				
44	Hexagon socket screw				
45	Hexagon socket screw				
52	Magnetic oil plug				
53.1	Compression nipple				
60	Parallel pin				
67	Toothed washer				
68	Key				
70	Toothed washer				
73	Set screw				
75	Gasket				
78	Gasket				
79	Holding clip or plastic tie				
80	Hexagon head screw				
84	Rear flange for brake				
85	Intermediate flange for backstop				
85.1	Intermediate flange for brake assembly				

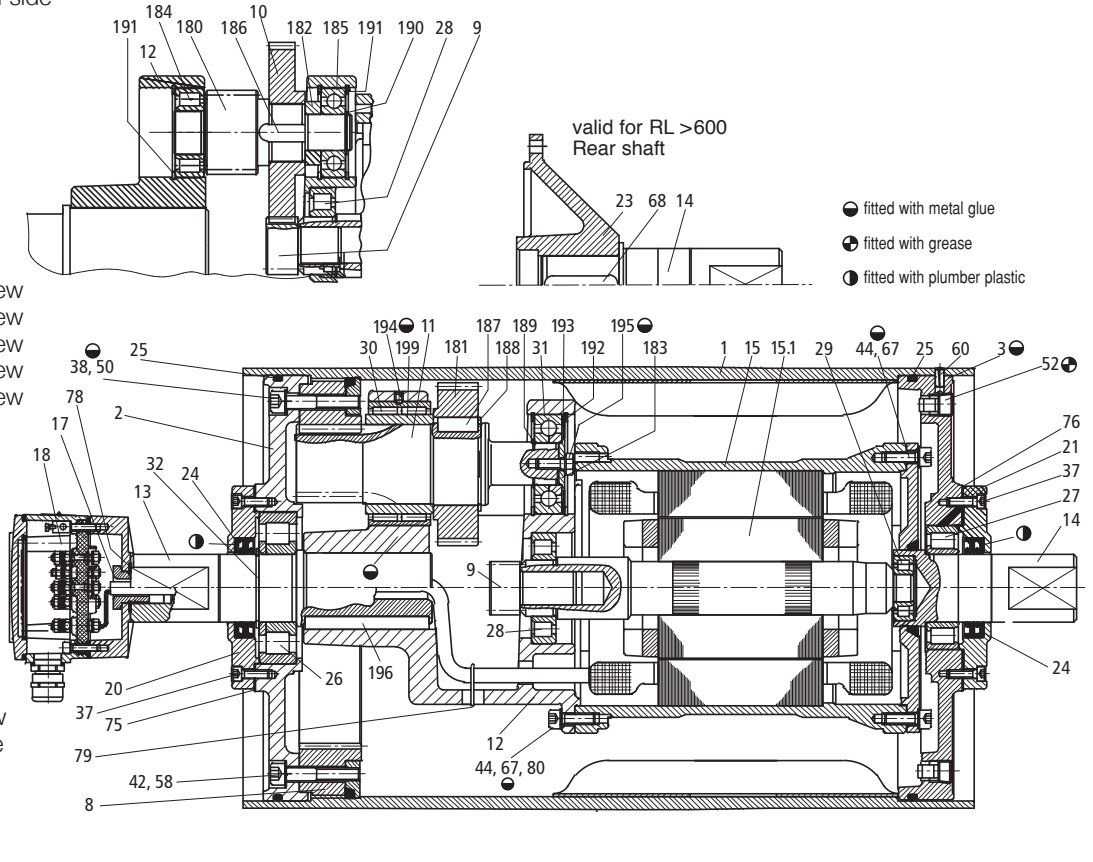

Motorized Pulley 320L, 320M & 320H, Ø 320 mm

Sectional drawings

Re-greaseable Labyrinth Option

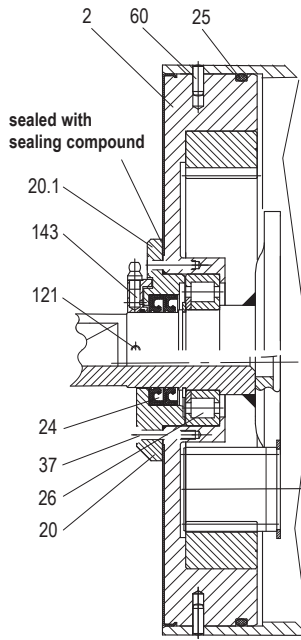
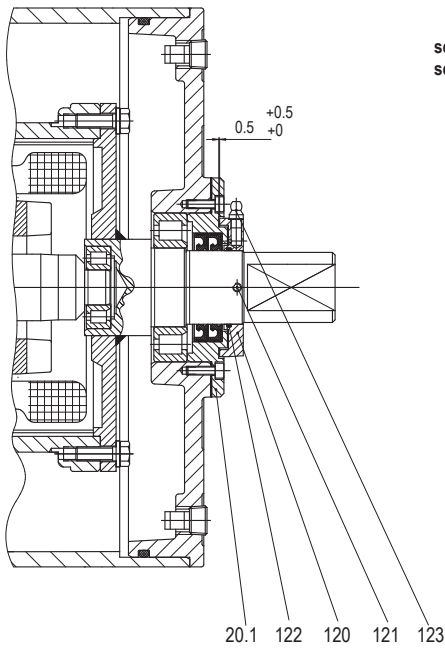

TS9N + TS11N
Labyrinth Option
valid for 320M

the pos. no. in brackets
(21 & 21.1) is valid for
320H 3-stage

TS10N + TS11N
without labyrinth

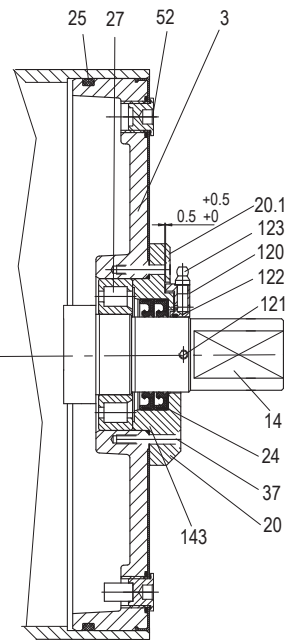

Stainless Steel Option

320L TS9N

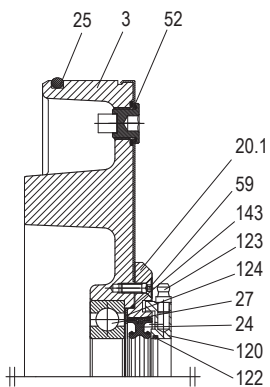

Elbow Connector

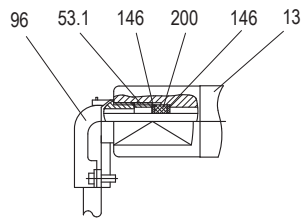

Straight Connector

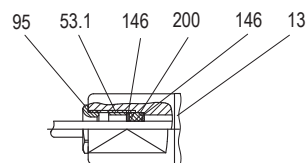

Electromagnetic Brake Option

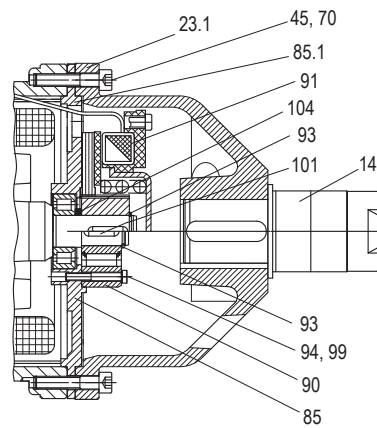

Backstop Option