

## transom A3 L-30°

For light upper troughing sets with three rollers, plain or with impact rings

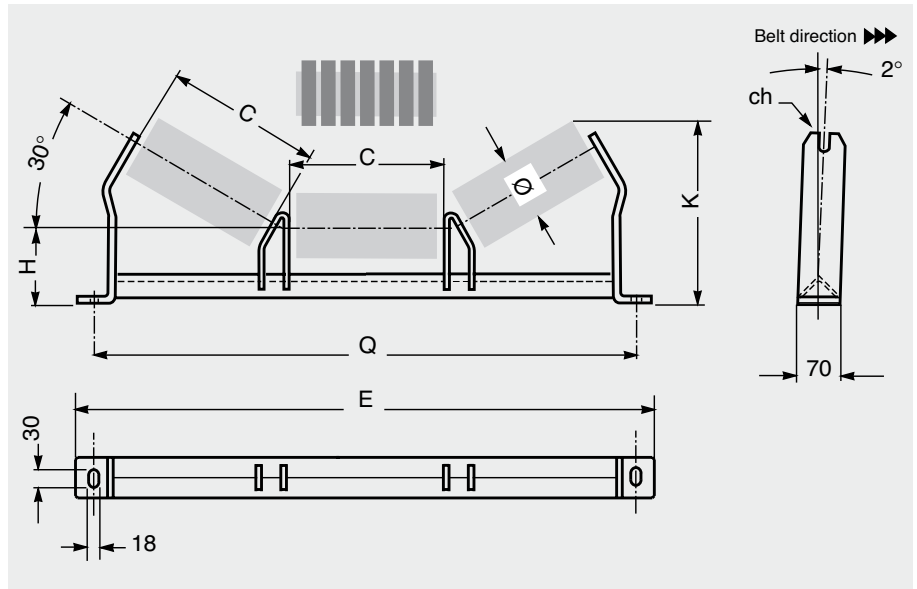

### for rollers series:

#### MPS

Ø 76, 89, 102  
spindle 15  
bearing 6202  
ch = 17

#### PL

Ø 90, 110  
PLF  
Ø 89, 108  
spindle 20  
bearing 6204  
ch = 30; 14

order codes	belt width mm	roller			transom					weight* without rollers Kg
		Ø mm	C	ch	capacity Kg	H mm	K max	Q	E	
A3 L /1A	400	76 - 89 - 90 102 - 108 - 110	168	17 - 30	286	125	267	640	700	5.4
A3 L /01	500		208		247	125	287	740	800	5.9
A3 L /03	650		258		205	125	312	890	950	6.6
A3 L /05	800		323		167	125	344	1090	1150	7.5

On request transoms may be supplied with different dimensions, characteristics and angles.



A3 L-30° Standard

### A3 LT-30° Special design with bracket

for fixing the transom without drilling the main frame

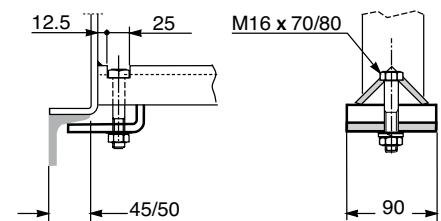

\* Add 1.5 kg for the special design with bracket

Example of ordering  
A3L/03, 650, F17, YA

for special designs  
see pages pag. 200